

# TIMING BELT PULLEYS-HUBLESS

20° PRESSURE ANGLE QUALITY NO. 10

**32 PITCH  
3/16 FACE  
.6871 BORE**

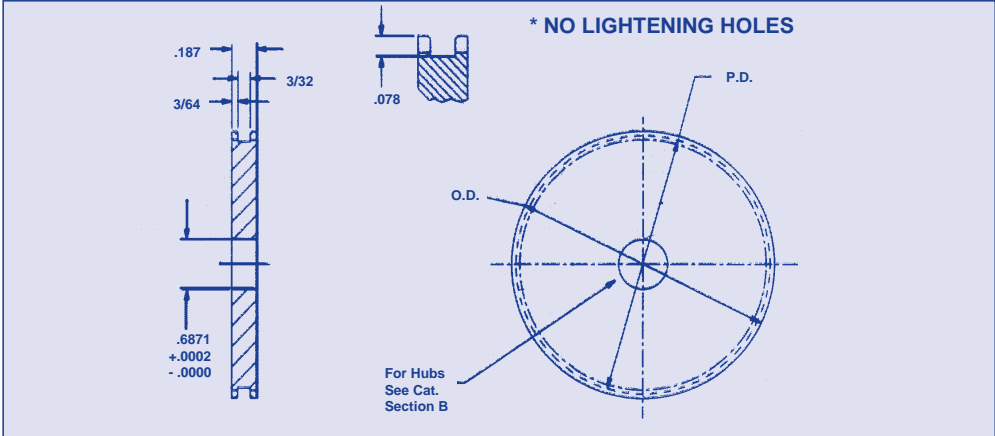

Gear tapes certifying accuracy available at additional cost.

**Material: 303 Stainless Steel  
2024-T4 Aluminum (Chromic Acid anodize - before cutting).**

STAINLESS STEEL		ALUMINUM	GEAR DATA		
Cat. No.	Cat. No.		No. of Teeth	Pitch Dia.	Outside Dia.
FKS-D9-48	FKA-D9-48		48	1.5000	1.563
FKS-D9-50	FKA-D9-50		50	1.5625	1.625
FKS-D9-56	FKA-D9-56		56	1.7500	1.813
FKS-D9-64	FKA-D9-64		64	2.0000	2.063
FKS-D9-72	FKA-D9-72		72	2.2500	2.313
FKS-D9-80	FKA-D9-80		80	2.5000	2.563
FKS-D9-88	FKA-D9-88		88	2.7500	2.813
FKS-D9-90	FKA-D9-90		90	2.8125	2.875
FKS-D9-96	FKA-D9-96		96	3.0000	3.063
FKS-D9-100	FKA-D9-100		100	3.1250	3.188
FKS-D9-112	FKA-D9-112		112	3.5000	3.563
FKS-D9-120	FKA-D9-120		120	3.7500	3.813
FKS-D9-128	FKA-D9-128		128	4.0000	4.063

Quality 12 and 14 on request - unlisted number of teeth supplied at modest additional cost.

\* LIGHTENING HOLES available upon request for sprockets 2 1/8 diameter and over.